



ARHA World Championship Show

Pattern Book

\$6

Ranchmanship- #3

Horse Show Classes– Junior, Senior, Amateur, Select, Youth, Novice Amateur, Novice Youth

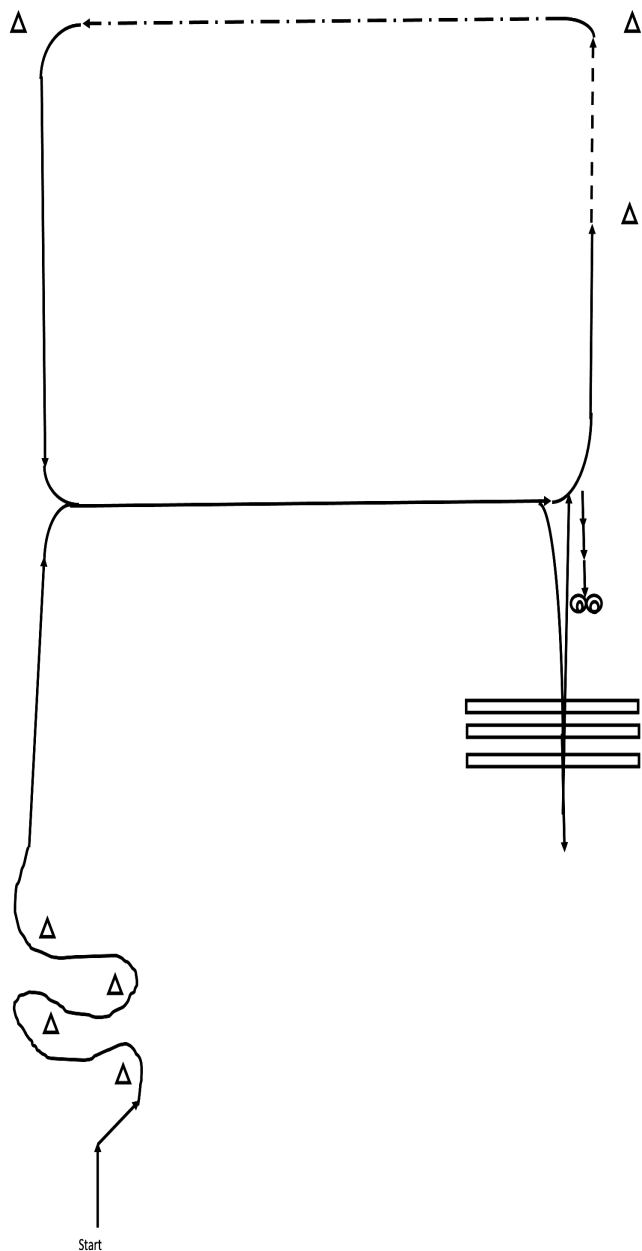

Ranchmanship

Pattern #3

1. Trot Serpentine through the cones.
2. Clear last cone; Right Lead Lope.
3. In Center Change to Left Lead.
4. Lope to cone; transition to walk.
5. Walk to next cone.
6. Extended Trot to next cone.
7. Pick up left lead to center.
8. Change to right.
9. Lope through crossover.
10. Stop, Roll Back Left.
11. Lope Back through lope over.
12. Stop Back 8-10 feet.
13. 2 Spins Right.
14. 2 Spins Left.

Ranchmanship Sweepstakes Prelims # 2

Ranchmanship Sweepstakes Finals #4

RANCHMANSHIP PATTERN #2

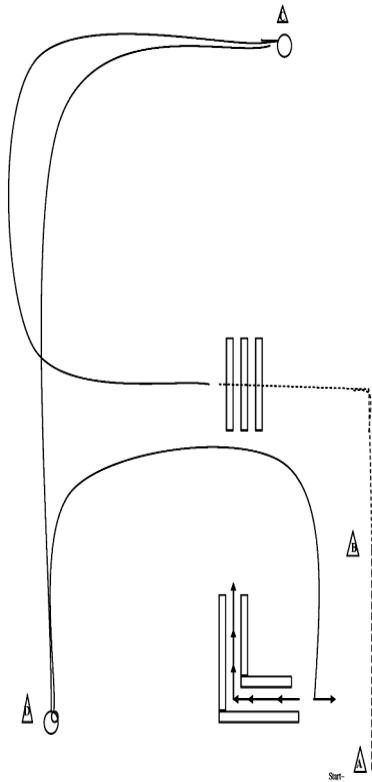

Ranchmanship

Pattern #2 PRELIMS

1. Walk A-B.
2. At cone trot to and over cross poles.
3. After poles are cleared Right lead lope.
4. At Cone ;Stop.
5. 1½ spin left.
6. Left lead lope to cone; Stop.
7. 1½ spins right.
8. Lope right lead to chute; Stop; 90° turn.
9. Back thru Chute.

RANCHMANSHIP

PATTERN #4 FINALS

1. Left lead lope A to B.
2. At B break to a trot.
3. Cross Over Poles.
4. Trot to next cone and stop.
5. Back 5 steps.
6. Left lead lope to center, small slow circle.
7. Stop.
8. 2 spins left.
9. Right lead lope small slow; in center change to left lead.
10. Continue to lope left lead into chute; in chute transition to walk.
11. Walk to log and side pass right.
12. Side pass left.

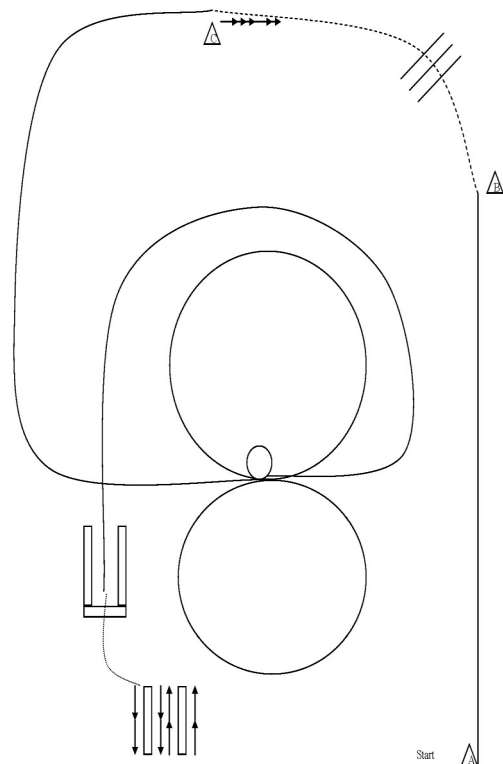

Reining– Junior, Senior, Amateur, & Youth

Pattern # 6

HORSES MUST TROT TO THE CENTER OF ARENA. HORSES MUST STOP PRIOR TO STARTING PATTERN. BEGINNING AT THE CENTER OF THE ARENA FACING THE LEFT WALL OR FENCE.

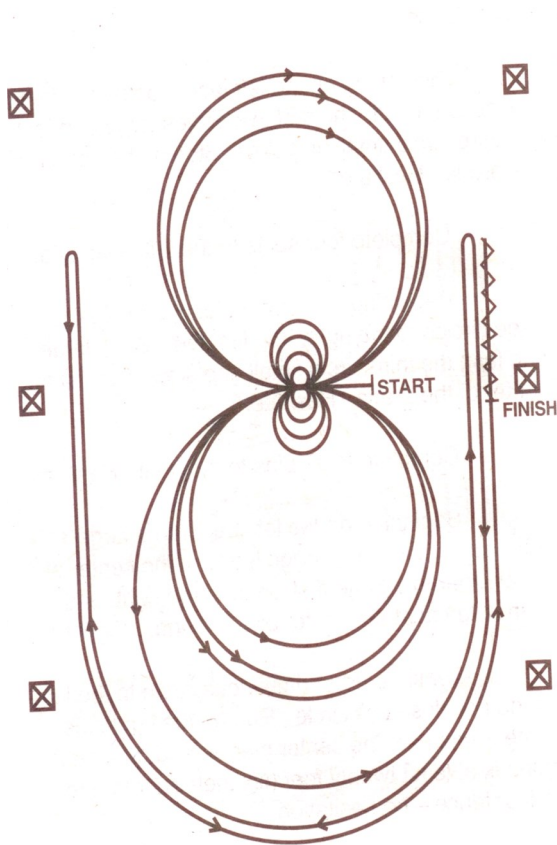

EXHIBITORS THAT DO NOT TROT IN WILL BE DISQUALIFIED.

1. Complete 4 spins to the right. Hesitate.
2. Complete 4 spins to the left. Hesitate.
3. Beginning on the left lead, complete 3 circles to the left; the first two circles large and fast, the third circle small and slow. Change leads at the center of the arena.
4. Complete three circles to the right; the first two circles large and fast, the third circle small and slow. Change leads at the center of the arena.
5. Begin a large fast circle to the left but do not close this circle. Run up the right side of the arena past the center marker and do a right rollback at least twenty feet from the wall or fence– no hesitation.
6. Continue back around previous circle but do not close this circle. Run up the left side of the arena past the center marker and do a left rollback at least twenty feet from the wall or fence.
7. Continue back around previous circle but do not close this circle. Run up the right side of the arena past the center marker and do a sliding stop at least twenty feet from the wall or fence. Back up at least 10 feet.

Hesitate to demonstrate the completion of the pattern.

Ranch Reining– Junior, Senior, Amateur/Select, Youth

RANCH REINING PATTERN #6

1. Run in past middle marker. Stop.
2. Back 8-10 feet to center of arena.
3. 3 spins to the right.
4. $3\frac{1}{4}$ to the left.
5. Begin on the right lead, lope circles , first large fast, second small slow; change leads to the left.
6. First circle small slow; second circle large fast; change leads.
7. Run down and stop. Roll back to the left.
8. Rundown and stop. Roll back to the right.
9. Run down and stop. Hesitate to show completion.

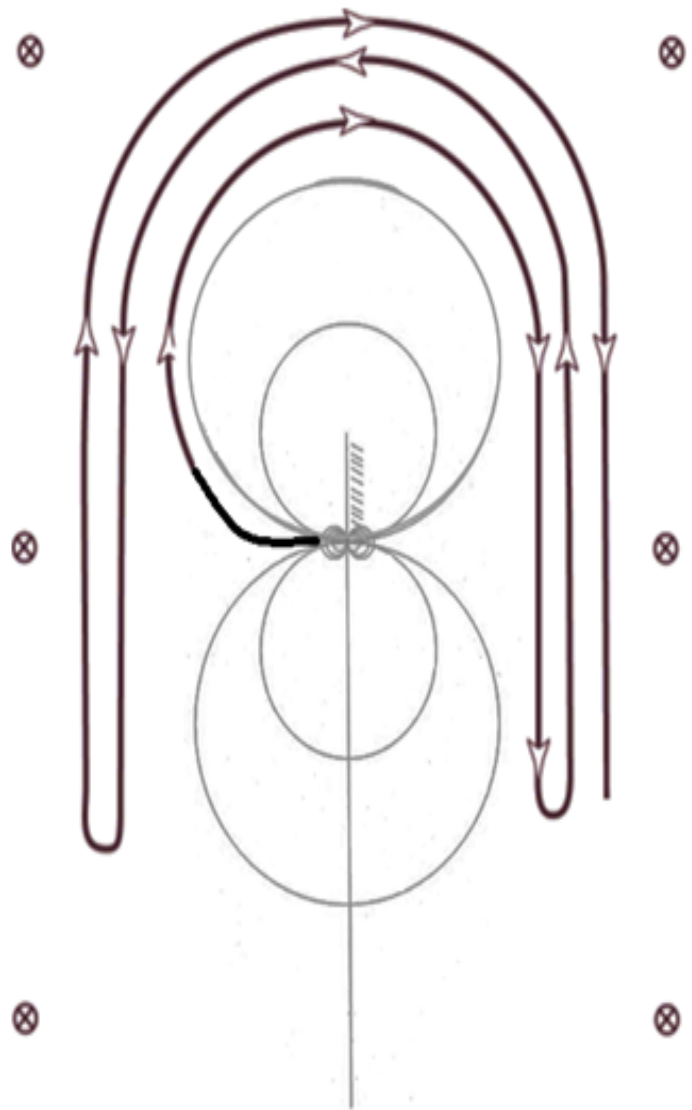

Ranch Reining– Novice Amateur, Novice Youth

NOVICE RANCH REINING PATTERN #3

HORSES MUST TROT TO THE CENTER OF THE ARENA. HORSES MUST STOP PRIOR TO STARTING THE PATTERN BEGINNING AT THE CENTER OF THE ARENA FACING THE ARENA FENCE.

1. Beginning on the left lead, complete 2 circles to the left. Stop at the center of the arena facing the left wall or fence.
2. Complete 2 spins to the left. Hesitate.
3. Beginning on the right lead complete 2 circles to the right. Stop at the center of the arena. Hesitate.
4. Complete 2 spins to the right. Hesitate.
5. Beginning on the left lead, go around the end of the arena, run down the right side of the arena past center marker, stop and roll back right.
6. Continue around the end of the arena to run down the left side of the arena past the center marker. Stop. Back up.

Rider may drop bridle to designated judge.

EXHIBITORS THAT DO NOT TROT IN WILL BE DISQUALIFIED.

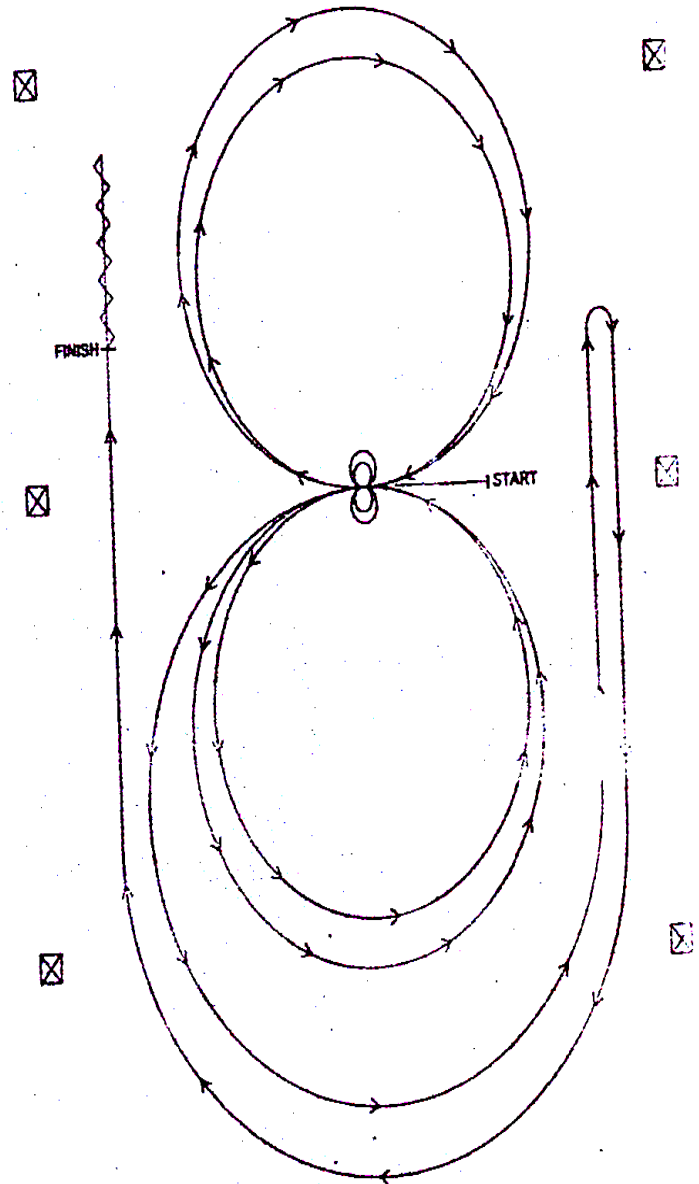

Working Cow Horse #9 Junior, Senior, Amateur (Select), Youth

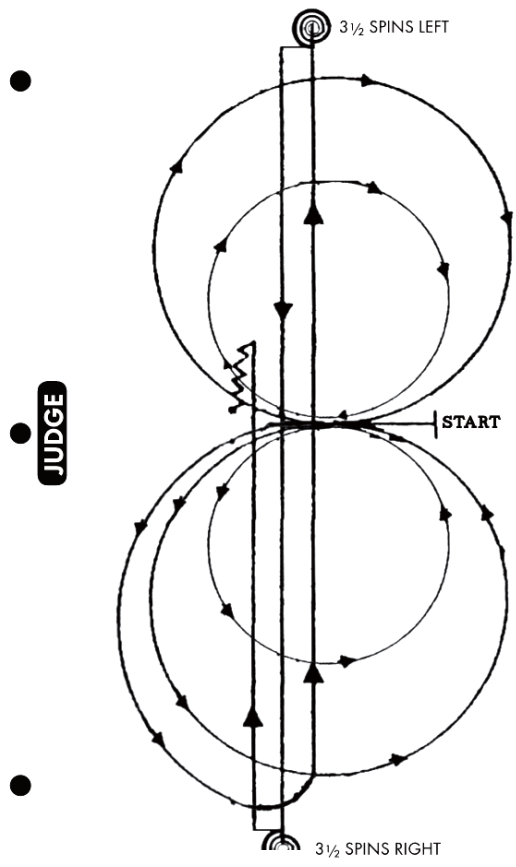

Trot to center of arena, stop. Start pattern facing towards the judge.

1. Beginning on the left lead complete 2 circles to the left, the first circle large and fast, and the second circle small and slow. Change leads at the center of the arena.
2. Complete 2 circles to the right, the first large and fast, the second circle small and slow. Change leads at the center of the arena.
3. Continue around end of arena without breaking gait or changing leads, run down center of the arena past without breaking gait or changing leads, run down center of the arena past the end marked, execute a square a square sliding stop.
4. Complete 3½ spins to the left.
5. Run down center of arena past end marker, execute a square sliding stop.
6. Complete 3½ spins to the right.
7. Run down center of arena past center marker, execute a square sliding stop. Back at least 10 feet. Hesitate to complete a square sliding stop. Back at least 10 feet. Hesitate to complete pattern.

America's Top Ranch Hand– Working Cow Horse Reined Work Pattern # 1 WORKING COW HORSE PATTERN# 1

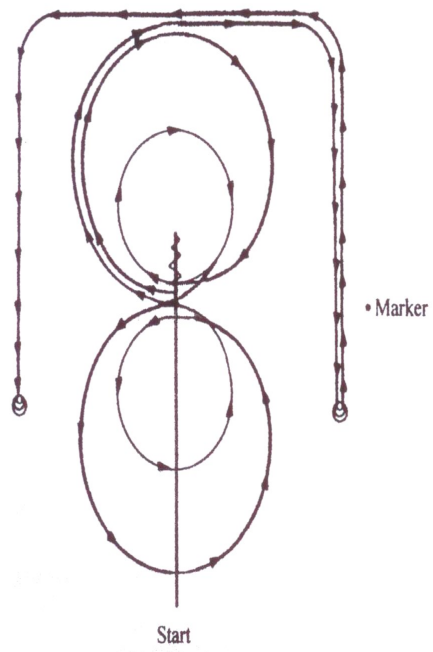

1. Start at end of the arena. Run down middle past center marker to a sliding stop.
2. Back at least 10 feet to center. 1/4 turn left.
3. Pickup right lead, large fast circle, small slow circle.
4. Change leads to left, large fast circle, small slow circle.
5. Change leads to right, do not close this circle.
6. Run around end of arena and down the side (approximately 20 feet from fence) Past center marker and come to a sliding stop.
7. Complete 3½ spins to the right.
8. Continue back down the side and end of the arena to other side (approximately 20 feet from fence) go past center marker and come to a sliding stop.
9. Complete 3½ spins to the left.
10. Hesitate to complete pattern.

2024 ARHA World Show
Amateur/ Amateur Select/ Youth Showmanship

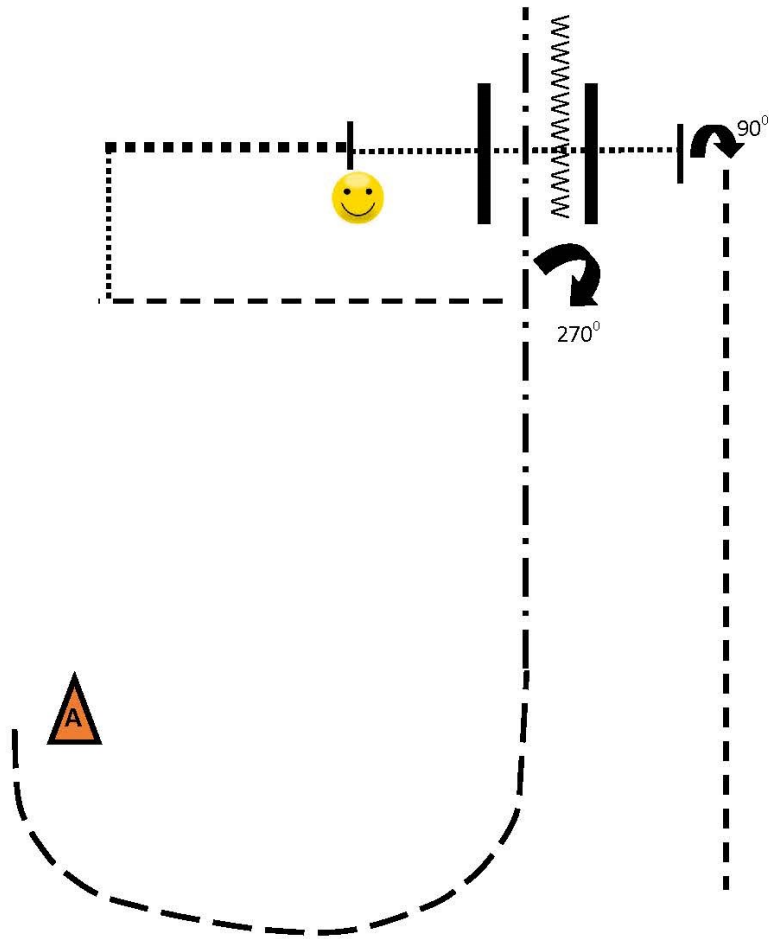

1. Begin at A, trot a half circle
2. Extend the trot through the chute until all four feet are on the other side of the chute
3. Back through the chute
4. 270° trot as shown and break to a walk in a square corner
5. Walk and then make another square corner
6. Extended walk until the horse's hip is even with the judge, stop
7. Set up for inspection
8. When dismissed, walk over the poles
9. Halt, set up and briefly hesitate
10. 90° and trot to exit

Horse and exhibitor are no longer being judged after they pass cone A

2024 ARHA World Show
Novice Amateur & Novice Youth Showmanship

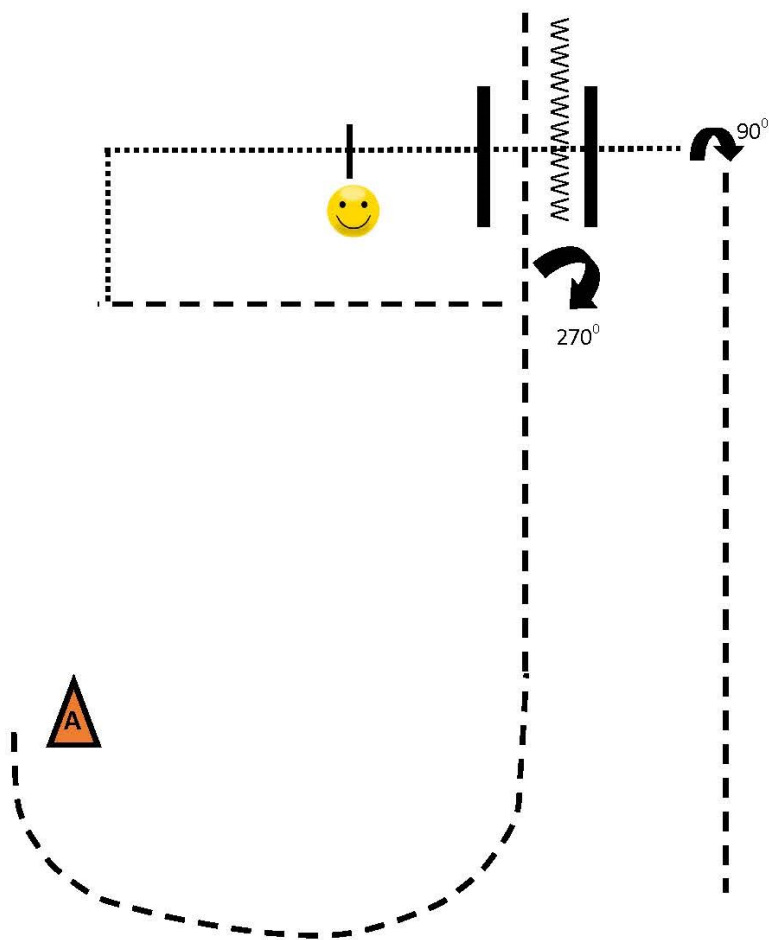

1. Begin at A, trot a half circle
2. Trot through the chute until all four feet are on the other side of the chute
3. Back through the chute
4. 270^o, trot as shown and break to a walk in a square corner
5. Walk and then make another square corner
6. Walk until the horse's hip is even with the judge, stop
7. Set up for inspection
8. When dismissed, walk over the poles
9. Halt, 90^o turn and trot to exit

Horse and exhibitor are no longer being judged after they pass cone A

2024 ARHA World Show
10 & Under Showmanship

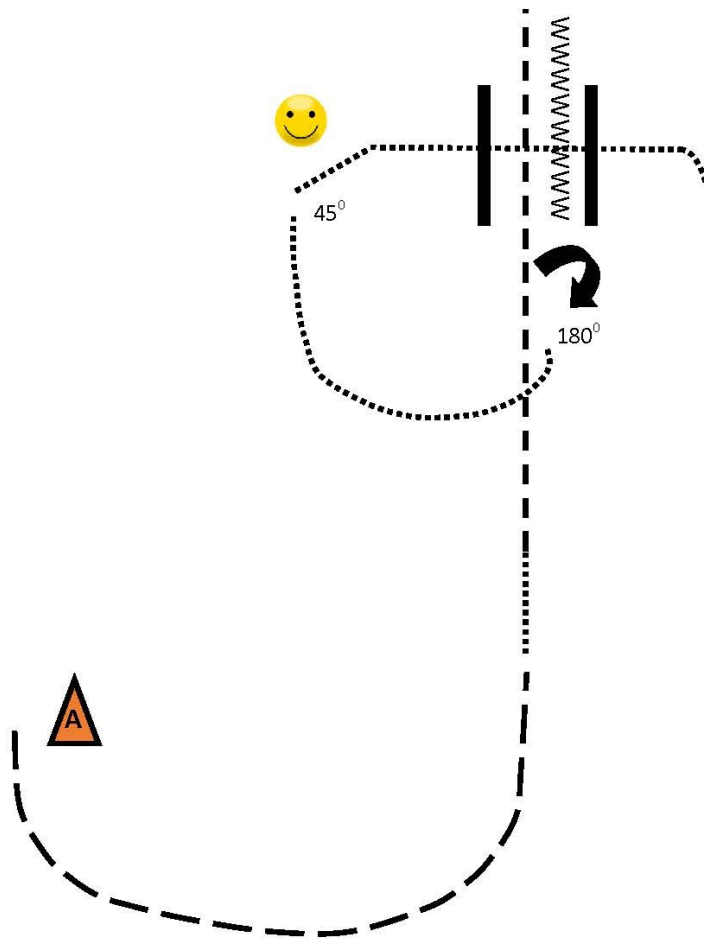

1. Begin at A. Trot a half circle
2. When even with A, break to a walk for 2 horse lengths
3. Trot through chute
4. Back through chute
5. 180, walk to judge as shown
6. Set up for inspection
7. 45° turn and walk away over poles to exit

Horse and exhibitor are no longer being judged after they walk over poles

ARHA World Show 2024
SR/JR/YTH/N-YTH/AMA/N-AMA/Select

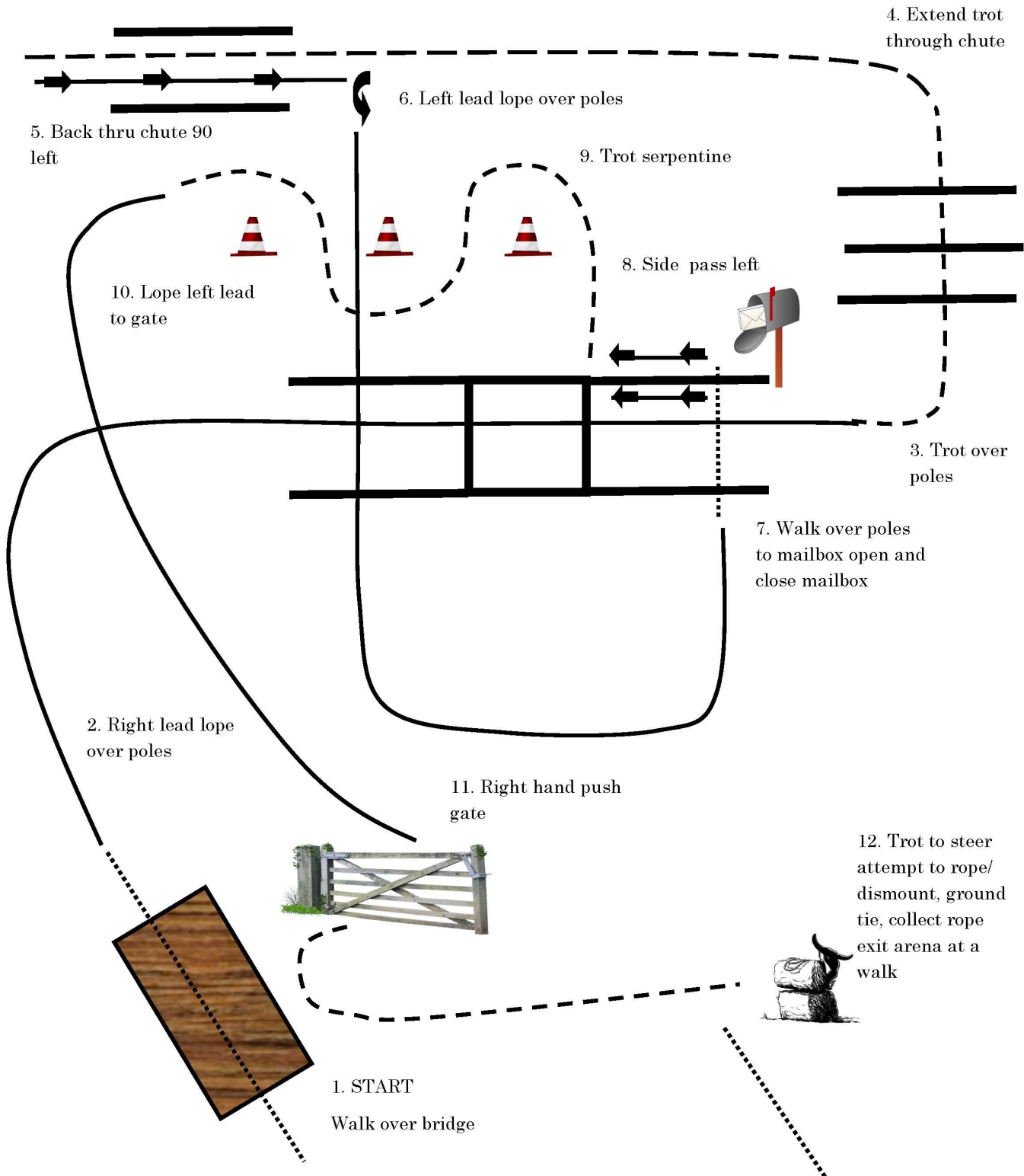

ARHA World Show 2024
10 & under Walk/Trot

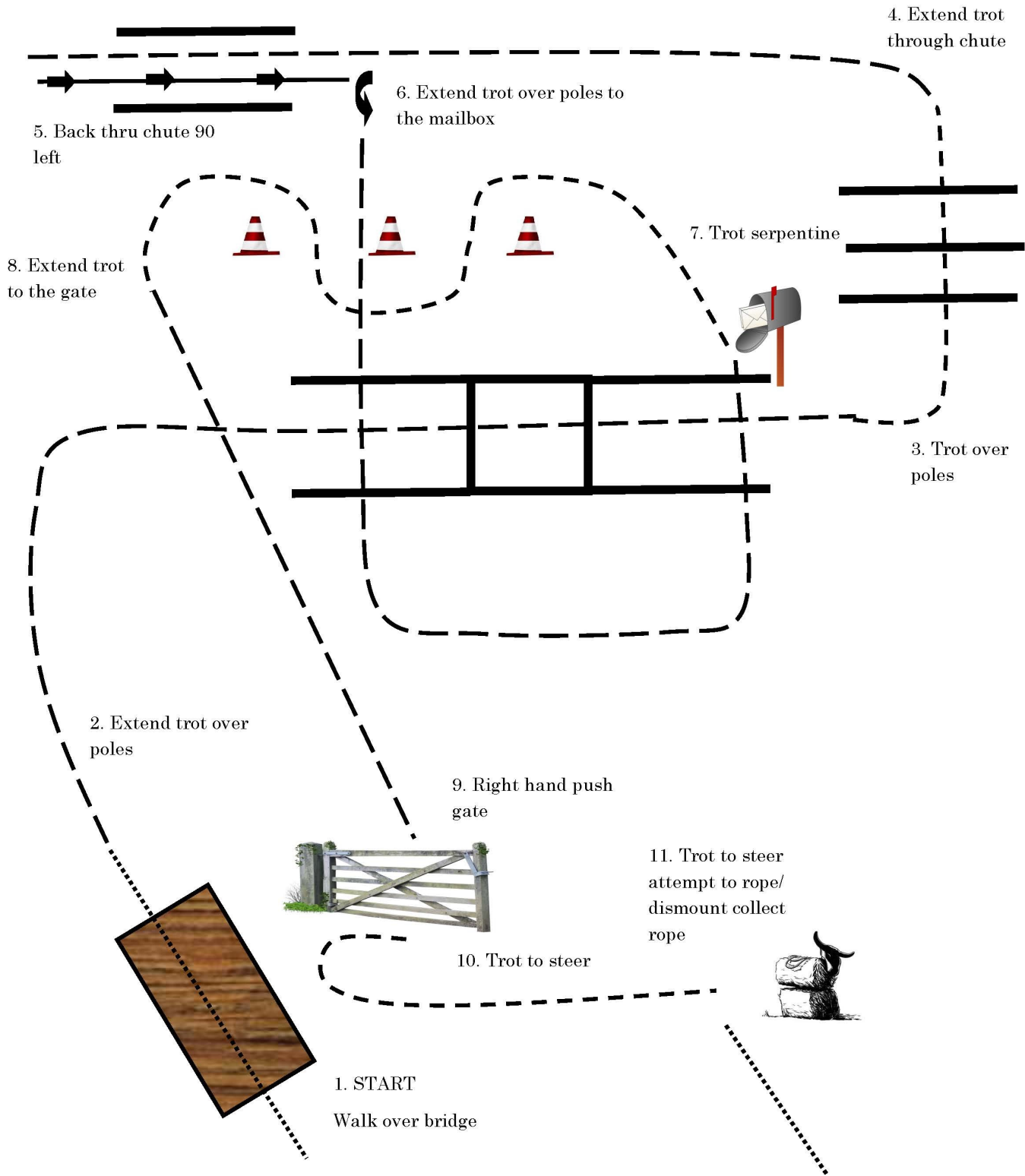

ARHA World Show 2024
In hand trail—2YR olds MUST be saddled

